



## CASH VALVE SERIES FR BACK PRESSURE VALVES

Diaphragm actuated valves designed for either continuous or intermittent operation which provide accurate, repetitive pressure control.



### FEATURES

- Protect against periodic high pressure, control dependably at adjusted pressures and shut tight.
- Maintain a pre-determined pressure on the inlet regardless of variations in pressure at the outlet.
- Unique full 'floating ring' seating arrangement provides smooth, even control in response to pressure changes.
- Globe type body with two side inlets and a bottom outlet, suitable for angle or in-line installation.
- Types FR and FR-6 fitted with a closing cap to discourage unauthorized tampering.
- Optional differential pressure control modification enables a constantly held difference between reference and valve inlet pressures.
- Type FR-6 incorporates a diaphragm ring above the diaphragm for higher back pressure ranges.
- Rugged, simple design enables easy on-line maintenance and repair.
- Optional cryogenic service construction available for handling cold fluids to -320°F (-195°C).

### GENERAL APPLICATION

For use on practically all fluids and gases except steam, these valves are especially suited for all grades of oils, including Bunker 'C', and may be used in centrifugal, regenerative turbine, reciprocating or rotary pump bypass valve applications.

### TECHNICAL DATA

Materials:	Bronze, cast iron, stainless steel (optional)
Sizes:	1/8" to 2" (3.2 to 50 mm)
Connections:	Threaded NPTF
Pressure range:	0 to 600 psig (0 to 41.4 barg)
Temperature range:	-320 to 600°F (-195 to 316°C)

# CASH VALVE SERIES FR BACK PRESSURE VALVES

## TYPES FR, FR-6, FR-10 MODELS OVERVIEW

When sized correctly, these valves will both open and close at predetermined points to provide accurate functional control for the continuous protection of pumps, process piping systems and similar equipment. They are not emergency devices, but are continuously operating valves which provide accurate, repetitive pressure control.

Sizes: 1/2", 3/4", 1", 1 1/4", 1 1/2" and 2" (15, 19, 25, 32, 38 and 50 mm).

FR Series valves are available in various pressure control and temperature ranges and are designated as follows:

- Type FR has a bronze body as standard, is suitable for pressures of 0-400 psig (0-27.6 barg) and maximum temperatures 200-600°F (93-316°C)\*.
- Type FR-6 incorporates a diaphragm ring mounted above the diaphragm to accommodate higher back pressure ranges: 200-600 psig (13.8-41 barg); 200-600°F (93-316°C)\*.
- The Type FR-10 is for more economical, lower pressure applications and is fitted with an iron body and spring chamber: 0-250 psig (0-17.2 barg); 450°F (232°C)\*

\* Minimum temperature for carbon steel is -20°F (-29°C).

## OPERATION

In a typical installation, inlet pressure enters from the side of the valve and registers under the diaphragm. When pressure rises above the set point of the valve, the diaphragm moves upward - away from the seat - allowing flow to pass through the bottom port. When inlet pressure drops below the setting of the valve, the diaphragm moves downward to the closed position.

## UNIQUE 'FLOATING RING' SEATING DESIGN

The valves' 'floating ring' principle compensates completely for unavoidable misalignment, producing perfect seat contact, free to move laterally in any direction to find its own correct alignment with the spherical seat disc.

It is thoroughly tested and proven to give far superior performance than ordinary valves using pistons and cylinders where good seat alignment is next to impossible. The diaphragm and seat disc are fastened together securely resulting in positive and rapid seat movement in response to all pressure changes.

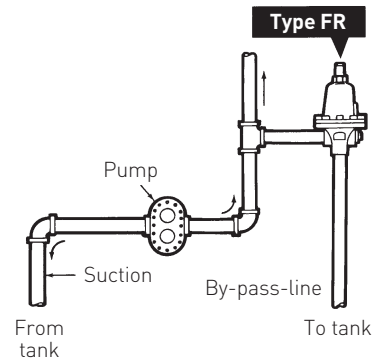

ANGLE VALVE INSTALLATION

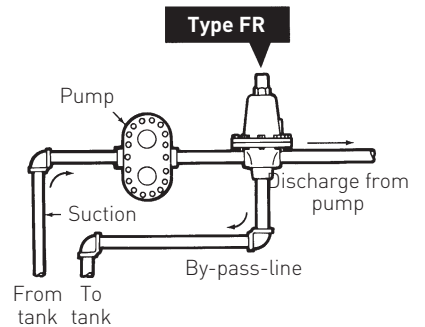

IN-LINE INSTALLATION (BOTTOM BY-PASS)

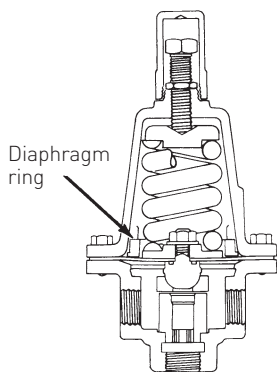

TYPE FR-6 INTERIOR VIEW

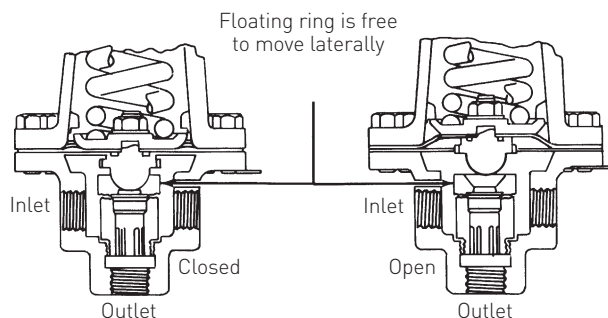

FLOATING RING DESIGN

# CASH VALVE SERIES FR BACK PRESSURE VALVES

## TYPES FR, FR-6, FR-10 CONSTRUCTION/SPECIFICATIONS

Series FR back pressure valves incorporate an iron or bronze body (iron standard on Type FR-10; carbon steel or stainless steel may be fitted to Types FR and FR-6 on special order) with threaded connections, bronze, Monel, stainless steel or NBR diaphragm; brass or stainless steel body seat, with a renewable stainless seat disc and seat ring.

### TYPE - FR, FR-6

Valve size	Dimensions					Shipping weight (lbs.)	
	A	B	C	D	E	Iron	Bronze
1/2"*	4 3/4"	6 3/4"	1 5/8"	1 7/16"	2 7/8"	8	9 1/2
3/4"	5 5/8"	8"	2"	1 11/16"	2 3/8"	13	14 3/4
1"	6 1/2"	10 5/16"	2 1/4"	2 1/8"	4 1/4"	20 1/4	23 1/2
1 1/4"	6 1/2"	10 7/16"	2 3/8"	2 1/8"	4 1/4"	21 1/2	24 1/2
1 1/2"	7 1/2"	10 3/4"	2 5/8"	2 1/2"	5"	29	33
2"	7 1/2"	11"	3"	2 1/2"	5"	31 1/2	35 1/2

Maximum operation temperature: 600°F

**Important:** all FR, FR-6 and FR-10 versions are furnished with a travel stop that prevents diaphragms from extending beyond their limit.

\* 1/2" FR only UL approved in iron body and metal diaphragm up to 150 psi.

### TYPE - FR-10

Valve size	Dimensions					Shipping weight (lbs.)	
	A	B	C	D	E	Iron	Bronze
1/2"	4 3/4"	6 9/16"	1 5/8"	1 7/16"	2 7/8"	7	
3/4"	5 5/8"	7 1/2"	2"	1 11/16"	3 3/8"	11 1/2	
1"	6 1/2"	8 1/2"	2 1/4"	2 1/8"	4 1/4"	18 1/4	
1 1/4"	6 1/2"	8 5/8"	2 3/8"	2 1/8"	4 1/4"	19 1/2	
1 1/2"	7 1/2"	10"	2 5/8"	2 1/2"	5"	27	
2"	7 1/2"	10 1/4"	3"	2 1/2"	5"	29 1/2	

Maximum operation temperature: 450°F

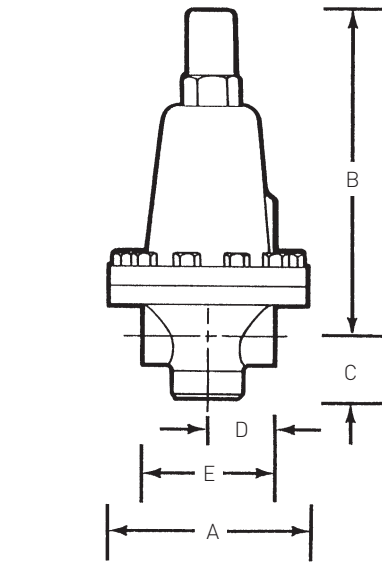

TYPE FR

# CASH VALVE SERIES FR BACK PRESSURE VALVES

## TYPES FRM, FRM-2 MODELS OVERVIEW

Types FRM and FRM-2 function as automatic pressure limiting regulators, maintaining a desired maximum pressure in a system or vessel by relieving excess pressure. They are small and compact, yet are highly efficient, making them suitable for numerous applications that call for a small accurate back pressure regulator for service on liquids, air and gases not corrosive to bronze.

- Furnished with either neoprene diaphragm or metal diaphragms in three body styles.
- Maximum temperature:
  - with neoprene diaphragm: 180°F (82°C).
  - with metal diaphragm: 500°F (260°C).
- Sizes: 1/8", 1/4", 3/8" and 1/2" (3.2, 7, 10.5 and 15 mm).
- Type FRM-2 is designed with larger physical dimensions and internal seat opening providing greater capacity. It is also suitable for fuel oils and lube oils and is available in stainless steel body with system exposed internal parts for service with corrosive or harsh fluids.
- Types FRM and FRM-2 incorporate the same superior 'floating ring' design as the larger Type FR to provide smooth, even pressure control.
- Optional cryogenic service construction is offered for the FRM and FRM-2 to enable them to be used for oxygen service suitable for temperatures to -320°F (-129°C).
- All versions fitted with adjusting screw as standard. Also available with T-handle and with bushing for mounting the valve to a control panel, on special order.
- All valves are furnished with a travel stop that prevents diaphragms from extending beyond their limit.

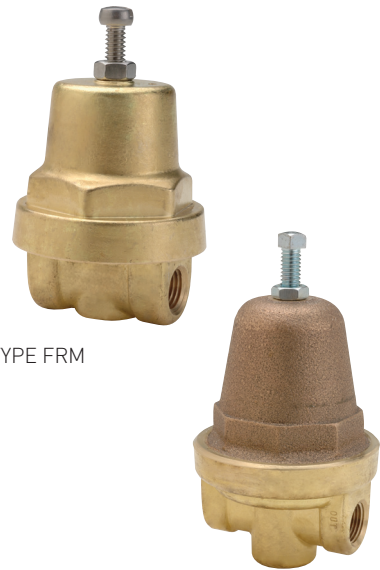

TYPE FRM

TYPE FRM-2

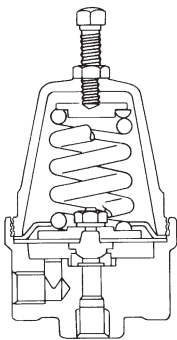

TYPE FRM-2  
SIDE INLET - BOTTOM OUTLET

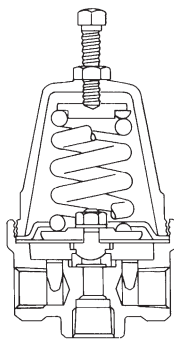

TYPE FRM-2  
TWO SIDE INLET - BOTTOM OUTLET

# CASH VALVE SERIES FR BACK PRESSURE VALVES

## TYPES FRM, FRM-2 CONSTRUCTION/SPECIFICATIONS

FRM Series are diaphragm-type miniature back pressure valves fitted with forged bronze bodies, bronze or aluminum (Type FRM only) spring chambers and neoprene or phosphor bronze diaphragms.

### FRM, FRM-2 DIAPHRAGM TYPE MINIATURE BACK PRESSURE VALVES

Type	Valve size	Relief press. range (psi)	Valve connections		
			S.I.-S.O.	S.I.-B.O.	2S.I.-B.O.
FRM	1/8"	0-175	X	X	(1)
FRM	1/4"	0-175	X	X	X
FRM	3/8"	0-175	X	X	
FRM-2*	1/4"	0-250	X	X	X
FRM-2*	3/8"	0-250	X	X	X
FRM-2*	1/2"	0-250	X	X	X

#### NOTES

- FRM only
  - Abbreviations used above are to be read as follows: S.I. = Side Inlet; 2S.I. = Two Side Inlets; S.O. = Side Outlet; B.O. = Bottom Outlet
- \* The Type FRM-2 is UL approved in all sizes and body styles with metal diaphragms up to 150 psi.

Type	Valve size	Dimensions			Shipping weight (lbs.)
		A	B	C	
FRM	1/8" x 1/8"	3 3/8"	1/2"	2 1/4"	1 1/8
FRM	1/4" x 1/4"	3 3/8"	1/2"	2 1/4"	1 1/8
FRM	3/8" x 3/8"	3 3/8"	1/2"	2 1/4"	1 1/8
FRM-2	1/4" x 1/4"	4 1/2"	3/4"	2 11/16"	2 1/2
FRM-2	3/8" x 3/8"	4 1/2"	3/4"	2 11/16"	2 1/2
FRM-2	1/2" x 1/2"	4 1/2"	1 1/8"	2 7/8"	3 1/2

## CAPACITY INFORMATION

The capacity charts for water are based on the specific gravity reading of water. If a liquid with a specific gravity other than that of water is being used in the system, it is necessary to apply a correction factor. For example, if a fluid to be used has a specific gravity reading of 1.5 and the given flow is 40 gpm: Refer to the specific gravity graph and find 1.5 on the vertical axis then read across to the diagonal intersect to obtain a S.G. factor of .8. Divide the given flow (40 gpm) by the .8 factor and obtain 50 gpm, the corrected flow for the fluid being used. Refer to the capacity charts to determine the correct valve size that should be used at the desired set pressure and at the corrected flow.

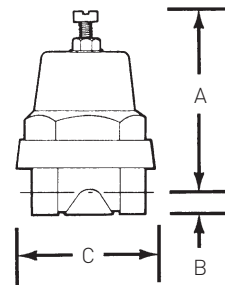

TYPE FRM

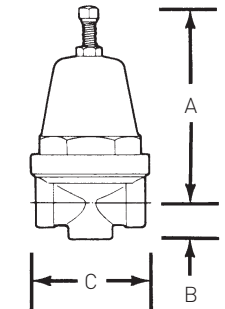

TYPE FRM-2

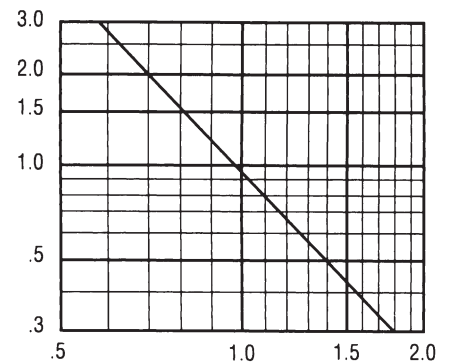

# CASH VALVE SERIES FR BACK PRESSURE VALVES

## TYPE FR, FR-6, FR-10 WATER CAPACITY (gpm)

				Inlet size 1/2"					
Types			Set pressure* (psig)	Rubber diaphragm			Metal diaphragm		
FR	FR-6	FR-10		10% Rise	20% Rise	30% Rise	10% Rise	20% Rise	30% Rise
X		X	10**	2.0	4.0	6.0	1.0	1.5	3.0
X		X	15	2.2	4.2	6.5	1.2	2.0	3.5
X		X	20	2.5	4.5	7.5	1.4	2.5	4.0
X		X	30	3.0	5.0	9.0	1.7	3.0	5.0
X		X	40	3.5	6.0	9.7	2.0	3.5	6.0
X		X	50	3.7	6.5	10.5	2.2	4.0	7.0
X		X	75	4.5	7.5	13.0	2.6	5.0	8.0
X		X	100	5.0	9.5	16.0	3.0	6.0	10.0
X		X	150	7.0	11.5	19.0	3.5	8.0	13.0
X	X	X	200	8.0	15.0	22.0	4.5	10.0	17.0
X	X		300	12.0	19.0	25.0	7.5	15.0	22.0
X	X		400	18.0	24.0	25.0	12.0	23.0	25.0
	X		600	21.0	25.0	25.0	16.0	25.0	25.0

## TYPE FR, FR-6, FR-10 WATER CAPACITY (gpm) (CONTINUED)

				Inlet size 3/4"					
Types			Set pressure* (psig)	Rubber diaphragm			Metal diaphragm		
FR	FR-6	FR-10		10% Rise	20% Rise	30% Rise	10% Rise	20% Rise	30% Rise
X		X	10**	3.0	6.0	8.0	1.8	3.5	5.5
X		X	15	3.2	6.2	8.5	2.0	4.5	6.5
X		X	20	3.5	6.7	10.0	2.5	5.0	7.5
X		X	30	4.0	7.2	11.5	3.0	6.0	9.5
X		X	40	4.5	8.5	12.5	3.5	7.0	11.0
X		X	50	4.7	9.5	14.5	4.0	8.0	12.0
X		X	75	5.5	11.5	17.0	5.0	10.0	14.0
X		X	100	6.0	14.0	21.0	6.0	11.0	16.0
X		X	150	9.0	18.0	25.0	7.0	15.0	20.0
X	X	X	200	11.0	21.5	30.0	9.0	17.0	24.0
X	X		300	16.0	26.5	30.0	13.0	20.0	28.0
X	X		400	23.0	30.0	30.0	17.0	28.0	30.0
	X		600	30.0	30.0	30.0	20.0	30.0	30.0

## TYPE FR, FR-6, FR-10 WATER CAPACITY (gpm) (CONTINUED)

				Inlet size 1"					
Types			Set pressure* (psig)	Rubber diaphragm			Metal diaphragm		
FR	FR-6	FR-10		10% Rise	20% Rise	30% Rise	10% Rise	20% Rise	30% Rise
X		X	10**	4.0	8.0	14.0	2.5	5.5	7.8
X		X	15	5.0	10.0	17.0	3.0	6.5	9.5
X		X	20	6.0	12.0	20.0	3.5	7.5	11.0
X		X	30	7.5	14.0	23.0	4.0	9.0	13.0
X		X	40	9.0	16.0	26.0	5.0	10.5	15.0
X		X	50	10.0	18.0	30.0	5.5	12.0	17.0
X		X	75	12.0	20.0	38.0	6.5	14.5	20.0
X		X	100	14.5	27.0	46.0	7.5	17.0	24.0
X		X	150	17.0	33.0	54.0	9.0	21.0	30.0
X	X	X	200	22.5	41.0	54.0	11.0	24.0	33.0
X	X		300	27.0	54.0	54.0	15.0	29.0	42.0
X	X		400	34.0	54.0	54.0	20.0	34.0	54.0
	X		600	54.0	54.0	54.0	24.0	50.0	54.0

### NOTES

\* Set pressures are based upon valve discharge into an atmospheric pressure return line. If return line pressure is significantly higher than atmospheric pressure, then consult factory for capacity information.

\*\* For set pressures less than 10 psi consult the factory.

# CASH VALVE SERIES FR BACK PRESSURE VALVES

## TYPE FR, FR-6, FR-10 WATER CAPACITY (gpm) (CONTINUED)

				Inlet size 1½"					
Types			Set pressure* (psig)	Rubber diaphragm			Metal diaphragm		
FR	FR-6	FR-10		10% Rise	20% Rise	30% Rise	10% Rise	20% Rise	30% Rise
X		X	10**	5.0	11.5	18.0	3.0	6.5	9.5
X		X	15	6.0	12.5	20.0	3.8	8.0	11.5
X		X	20	7.0	14.0	23.0	4.5	9.0	13.5
X		X	30	8.0	16.0	27.0	5.5	11.5	16.5
X		X	40	10.0	18.0	31.0	6.3	13.2	19.0
X		X	50	11.0	20.0	34.0	7.0	14.7	21.5
X		X	75	13.0	24.0	42.0	8.5	18.0	26.0
X		X	100	16.0	32.0	50.0	9.8	21.0	30.0
X		X	150	20.0	44.0	66.0	12.0	25.5	40.0
X	X	X	200	25.0	55.0	80.0	14.0	29.5	53.0
X	X		300	34.0	70.0	80.0	17.0	36.0	80.0
X	X		400	42.0	80.0	80.0	22.0	48.0	80.0
	X		600	65.0	80.0	80.0	44.0	80.0	80.0

## TYPE FR, FR-6, FR-10 WATER CAPACITY (gpm) (CONTINUED)

				Inlet size 1½"					
Types			Set pressure* (psig)	Rubber diaphragm			Metal diaphragm		
FR	FR-6	FR-10		10% Rise	20% Rise	30% Rise	10% Rise	20% Rise	30% Rise
X		X	10**	6.0	13.0	20.0	4.2	7.8	11.8
X		X	15	7.0	14.0	23.0	5.0	9.5	14.2
X		X	20	8.0	15.0	27.0	6.0	11.0	16.5
X		X	30	9.0	18.0	30.0	7.2	13.5	20.0
X		X	40	11.0	20.0	34.0	8.5	15.5	23.5
X		X	50	13.0	23.0	40.0	9.5	17.3	26.0
X		X	75	15.0	32.0	49.0	11.5	21.0	36.0
X		X	100	18.0	40.0	60.0	13.2	24.5	48.0
X		X	150	22.0	54.0	77.0	16.2	30.0	62.0
X	X	X	200	27.0	70.0	93.0	19.0	40.0	80.0
X	X		300	39.0	95.0	110.0	23.0	53.0	100.0
X	X		400	50.0	120.0	120.0	26.0	66.0	120.0
	X		600	80.0	120.0	120.0	50.0	80.0	120.0

## TYPE FR, FR-6, FR-10 WATER CAPACITY (gpm) (CONTINUED)

				Inlet size 2"					
Types			Set pressure* (psig)	Rubber diaphragm			Metal diaphragm		
FR	FR-6	FR-10		10% Rise	20% Rise	30% Rise	10% Rise	20% Rise	30% Rise
X		X	10**	7	15	23	4.3	9.4	14.5
X		X	15	8	16	26	5.2	11.5	17.5
X		X	20	9	17	30	6.3	13.0	20.0
X		X	30	10	20	34	7.5	16.0	25.0
X		X	40	13	22	44	9.0	19.0	29.0
X		X	50	15	26	58	10.0	21.0	35.0
X		X	75	17	40	80	12.0	25.0	55.0
X		X	100	20	48	92	13.5	30.0	65.0
X		X	150	25	66	118	16.5	44.0	83.0
X	X	X	200	30	82	144	19.5	56.0	102.0
X	X		300	43	110	200	24.0	80.0	130.0
X	X		400	61	130	200	34.0	100.0	156.0
	X		600	108	162	200	64.0	136.0	200.0

### NOTES

\* Set pressures are based upon valve discharge into an atmospheric pressure return line. If return line pressure is significantly higher than atmospheric pressure, then consult factory for capacity information.

\*\* For set pressures less than 10 psi consult the factory.

# CASH VALVE SERIES FR BACK PRESSURE VALVES

## TYPE FR, FR-6, FR-10 AIR CAPACITY (SCFM)

				Inlet size 1/2"					
Types			Set pressure* (psig)	Rubber diaphragm			Metal diaphragm		
FR	FR-6	FR-10		10% Rise	20% Rise	30% Rise	10% Rise	20% Rise	30% Rise
X		X	10**	7	15	22	3	7	10
X		X	15	8	17	30	4	9	14
X		X	20	10	19	38	5	10	16
X		X	30	13	24	48	7	13	20
X		X	40	16	34	56	8	17	25
X		X	50	19	44	72	10	19	34
X		X	75	30	56	90	11	23	44
X		X	100	40	74	108	12	32	60
X		X	150	60	104	150	14	46	84
X	X	X	200	92	140	200	16	60	120
X	X		300	140	210	300	22	90	160
X	X		400	180	280	400	35	120	240
	X		600	280	420	600	50	180	320

## TYPE FR, FR-6, FR-10 AIR CAPACITY (SCFM) (CONTINUED)

				Inlet size 3/4"					
Types			Set pressure* (psig)	Rubber diaphragm			Metal diaphragm		
FR	FR-6	FR-10		10% Rise	20% Rise	30% Rise	10% Rise	20% Rise	30% Rise
X		X	10**	10	24	30	6	12	19
X		X	15	15	30	48	8	15	24
X		X	20	20	38	62	10	18	32
X		X	30	25	48	80	12	22	42
X		X	40	31	62	120	15	25	50
X		X	50	38	74	150	20	30	58
X		X	75	48	86	225	25	36	63
X		X	100	60	96	300	32	50	80
X		X	150	86	144	440	40	72	120
X	X	X	200	128	180	600	46	100	160
X	X		300	190	270	850	54	145	240
X	X		400	240	360	1200	65	200	320
	X		600	380	540	1700	80	290	480

## TYPE FR, FR-6, FR-10 AIR CAPACITY (SCFM) (CONTINUED)

				Inlet size 1"					
Types			Set pressure* (psig)	Rubber diaphragm			Metal diaphragm		
FR	FR-6	FR-10		10% Rise	20% Rise	30% Rise	10% Rise	20% Rise	30% Rise
X		X	10**	15	32	45	9	18	29
X		X	15	30	50	72	12	23	38
X		X	20	40	65	94	14	27	46
X		X	30	50	85	120	17	34	58
X		X	40	60	98	180	20	38	68
X		X	50	72	110	230	27	45	80
X		X	75	90	124	340	35	54	95
X		X	100	112	140	450	42	75	120
X		X	150	140	210	680	50	108	180
X	X	X	200	168	280	900	56	150	240
X	X		300	240	420	1250	66	215	360
X	X		400	320	560	1800	77	300	480
	X		600	480	820	2500	98	430	720

### NOTES

\* Set pressures are based upon valve discharge into an atmospheric pressure return line. If return line pressure is significantly higher than atmospheric pressure, then consult factory for capacity information.

\*\* For set pressures less than 10 psi consult the factory.

# CASH VALVE SERIES FR BACK PRESSURE VALVES

## TYPE FR, FR-6, FR-10 AIR CAPACITY (SCFM) (CONTINUED)

				Inlet size 1½"					
Types			Set pressure* (psig)	Rubber diaphragm			Metal diaphragm		
FR	FR-6	FR-10		10% Rise	20% Rise	30% Rise	10% Rise	20% Rise	30% Rise
X		X	10**	22	40	60	11	22	35
X		X	15	38	60	90	15	29	56
X		X	20	48	80	134	22	35	76
X		X	30	60	128	172	28	45	90
X		X	40	72	148	190	32	60	96
X		X	50	82	166	250	36	66	102
X		X	75	106	185	375	42	78	120
X		X	100	130	225	500	50	96	180
X		X	150	160	275	750	58	120	240
X	X	X	200	200	350	1000	64	160	360
X	X		300	300	500	1450	82	250	480
X	X		400	400	700	1950	120	350	700
	X		600	600	1000	2850	160	500	950

## TYPE FR, FR-6, FR-10 AIR CAPACITY (SCFM) (CONTINUED)

				Inlet size 1½"					
Types			Set pressure* (psig)	Rubber diaphragm			Metal diaphragm		
FR	FR-6	FR-10		10% Rise	20% Rise	30% Rise	10% Rise	20% Rise	30% Rise
X		X	10**	40	74	75	20	30	55
X		X	15	55	98	120	25	42	68
X		X	20	72	124	192	32	58	100
X		X	30	92	158	250	38	68	120
X		X	40	112	175	280	42	85	140
X		X	50	134	200	320	47	95	150
X		X	75	155	225	450	55	115	165
X		X	100	180	280	640	64	135	240
X		X	150	210	380	900	80	180	320
X	X	X	200	260	500	1250	100	250	480
X	X		300	400	700	1750	150	320	640
X	X		400	520	1000	2400	200	500	950
	X		600	800	1400	3450	300	650	1250

## TYPE FR, FR-6, FR-10 AIR CAPACITY (SCFM) (CONTINUED)

				Inlet size 2"					
Types			Set pressure* (psig)	Rubber diaphragm			Metal diaphragm		
FR	FR-6	FR-10		10% Rise	20% Rise	30% Rise	10% Rise	20% Rise	30% Rise
X		X	10**	64	112	144	32	48	80
X		X	15	88	144	208	40	64	104
X		X	20	112	184	296	48	88	150
X		X	30	136	224	384	55	104	172
X		X	40	152	248	424	62	120	200
X		X	50	170	280	488	70	144	215
X		X	75	190	312	650	82	168	240
X		X	100	240	410	850	92	200	320
X		X	150	300	550	1100	120	272	475
X	X	X	200	400	750	1700	152	352	640
X	X		300	624	1050	2100	220	480	950
X	X		400	800	1500	3150	300	700	1250
	X		600	1200	2100	4000	400	960	1750

### NOTES

\* Set pressures are based upon valve discharge into an atmospheric pressure return line. If return line pressure is significantly higher than atmospheric pressure, then consult factory for capacity information.

\*\* For set pressures less than 10 psi consult the factory.

# CASH VALVE SERIES FR BACK PRESSURE VALVES

## TYPE FRM WATER CAPACITY (GPM)

Set pressure* (psig)	Inlet size 1/8"				Inlet size 1/4"	
	Rubber diaphragm		Metal diaphragm		Rubber diaphragm	
	10% Rise	20% Rise	10% Rise	20% Rise	10% Rise	20% Rise
10**	0.2	0.7	0.1	0.5	0.2	0.7
25	0.5	1.2	0.5	1.0	0.5	1.2
50	1.2	2.5	0.7	1.7	1.2	2.5
100	2.1	3.0	1.4	3.0	2.1	3.5
150	2.5	3.0	1.5	3.0	2.5	4.8

## TYPE FRM WATER CAPACITY (GPM) (CONTINUED)

Set pressure* (psig)	Inlet size 1/4"		Inlet size 3/8"			
	Metal diaphragm		Rubber diaphragm		Metal diaphragm	
	10% Rise	20% Rise	10% Rise	20% Rise	10% Rise	20% Rise
10**	0.1	0.5	0.2	0.7	0.1	0.5
25	0.5	1.0	0.5	1.2	0.5	1.0
50	0.7	1.7	1.2	2.5	0.7	1.7
100	1.4	3.0	2.1	3.5	1.4	3.0
150	1.5	4.0	2.5	4.8	1.5	4.0

## TYPE FRM AIR CAPACITY (SCFM)

Set pressure* (psig)	Inlet size 1/8"				Inlet size 1/4"	
	Rubber diaphragm		Metal diaphragm		Rubber diaphragm	
	10% Rise	20% Rise	10% Rise	20% Rise	10% Rise	20% Rise
10**	0.5	1.5	0.3	0.9	0.5	1.5
25	2.1	6.5	1.2	4.0	2.1	6.5
50	5.0	16.0	2.6	9.5	5.0	16.0
100	12.0	25.0	6.5	15.0	12.0	25.0
150	16.0	35.0	11.5	25.0	16.0	35.0

## TYPE FRM AIR CAPACITY (SCFM) (CONTINUED)

Set pressure* (psig)	Inlet size 1/4"		Inlet size 3/8"			
	Metal diaphragm		Rubber diaphragm		Metal diaphragm	
	10% Rise	20% Rise	10% Rise	20% Rise	10% Rise	20% Rise
10**	0.3	0.9	0.5	1.5	0.3	0.9
25	1.2	4.0	2.1	6.5	1.2	4.0
50	2.6	9.5	5.0	16.0	2.6	9.5
100	6.5	15.0	12.0	25.0	6.5	15.0
150	11.5	25.0	16.0	35.0	11.5	25.0

### NOTES

- \* Set pressures are based upon valve discharge into an atmospheric pressure return line. If return line pressure is significantly higher than atmospheric pressure, then consult factory for capacity information.
- \*\* For set pressures less than 10 psi consult the factory.

# CASH VALVE SERIES FR BACK PRESSURE VALVES

## TYPE FRM-2 WATER CAPACITY (GPM)

Set pressure* (psig)	Inlet size ¼"				Inlet size ⅜"	
	Rubber diaphragm		Metal diaphragm		Rubber diaphragm	
	10% Rise	20% Rise	10% Rise	20% Rise	10% Rise	20% Rise
10**	0.5	1.0	0.3	0.7	0.5	1.0
25	0.7	1.7	0.7	1.2	0.7	1.7
50	1.5	3.5	1.0	2.0	1.5	3.5
100	2.7	5.0	2.0	4.0	2.7	5.0
150	3.7	7.5	2.5	5.5	3.7	7.5
200	4.5	8.5	3.0	6.5	4.5	8.5
250	5.5	10.0	4.0	8.0	5.5	10.0

## TYPE FRM-2 WATER CAPACITY (GPM) (CONTINUED)

Set pressure* (psig)	Inlet size ⅜"		Inlet size ½"			
	Metal diaphragm		Rubber diaphragm		Metal diaphragm	
	10% Rise	20% Rise	10% Rise	20% Rise	10% Rise	20% Rise
10**	0.3	0.7	0.5	1.0	0.3	0.7
25	0.7	1.2	0.7	1.7	0.7	1.2
50	1.0	2.0	1.5	3.5	1.0	2.0
100	2.0	4.0	2.7	5.0	2.0	4.0
150	2.5	5.5	3.7	7.5	2.5	5.5
200	3.0	6.5	4.5	8.5	3.0	6.5
250	4.0	8.0	5.5	10.0	4.0	8.0

## TYPE FRM-2 AIR CAPACITY (SCFM)

Set pressure* (psig)	Inlet size ¼"				Inlet size ⅜"	
	Rubber diaphragm		Metal diaphragm		Rubber diaphragm	
	10% Rise	20% Rise	10% Rise	20% Rise	10% Rise	20% Rise
10**	5.0	11.0	3.0	8.0	5.0	11.0
25	9.0	14.0	5.0	11.0	9.0	14.0
50	12.0	22.0	7.0	17.0	12.0	22.0
100	16.0	33.0	11.0	25.0	16.0	33.0
150	20.0	42.0	14.0	31.0	20.0	42.0
200	24.0	52.0	17.0	38.0	24.0	52.0
250	26.0	60.0	20.0	43.0	26.0	60.0

## TYPE FRM-2 AIR CAPACITY (SCFM) (CONTINUED)

Set pressure* (psig)	Inlet size ⅜"		Inlet size ½"			
	Metal diaphragm		Rubber diaphragm		Metal diaphragm	
	10% Rise	20% Rise	10% Rise	20% Rise	10% Rise	20% Rise
10**	3.0	8.0	5.0	11.0	3.0	8.0
25	5.0	11.0	9.0	14.0	5.0	11.0
50	7.0	17.0	12.0	22.0	7.0	17.0
100	11.0	25.0	16.0	33.0	11.0	25.0
150	14.0	31.0	20.0	42.0	14.0	31.0
200	17.0	38.0	24.0	52.0	17.0	38.0
250	20.0	43.0	26.0	60.0	20.0	43.0

### NOTES

\* Set pressures are based upon valve discharge into an atmospheric pressure return line. If return line pressure is significantly higher than atmospheric pressure, then consult factory for capacity information.

\*\* For set pressures less than 10 psi consult the factory.

## CASH VALVE SERIES FR BACK PRESSURE VALVES

### SELECTION INFORMATION

Maximum temperature °F	Body material				Body seat		Seat ring and disc	
	Iron	Bronze	Steel	316 S. St.	Brass	303 S. St.	316 S. St.	303 S. St. 316 S. St.
200	X				X			X
450	X				X			X
450	X					X		X
450	X				X	X		X
200		X			X			X
450		X						X
450		X			X	X		X
-320		X				X		X
600			X			X		X
200				X			X	X
600				X			X	X
200				X		X		X
600				X		X		X

### SELECTION INFORMATION (CONTINUED)

Maximum temperature °F	NBR	Diaphragm			O-ring		Diaph. gasket	
		Bronze	316 S. St.	Monel®	NBR	PTFE	HI temp.	PTFE
200	X				X			
450		X				X	X	
450			X			X	X	
450				X		X	X	
200	X				X			
450		X				X	X	
450				X		X	X	
-320		X				X		X
600				X	*	*	X	
200	X				X			
600				X	*	*	X	
200	X				X			
600			X		*	*	X	

\* Special gasket furnished in lieu of O-ring for 600°F.

### APPLICATIONS

The charts show maximum temperature limits for various bodies and component part materials which are available as standard. Marked squares show how the valve will be trimmed internally to meet particular temperature requirements. Many combinations for specific service are possible. When in doubt, consult the factory.

# CASH VALVE SERIES FR BACK PRESSURE VALVES

## SELECTION GUIDE

Example:	FR-	Z	A	W	T	C	Z	Z	B	S	01	-	D	1
<b>Model</b>														
<b>FR6</b>	FR-6													
<b>FR1</b>	FR-10													
<b>FR-</b>	FR													
<b>Material of construction</b>														
<b>Z</b>	Bronze (FR, FR-6)	<b>G</b>	316 SST (FR, FR-6)											
<b>F</b>	Iron (FR, FR-10)													
<b>Valve size</b>														
<b>C</b>	½"	<b>F</b>	1¼"											
<b>D</b>	¾"	<b>G</b>	1½"											
<b>E</b>	1"	<b>H</b>	2"											
<b>Service</b>														
<b>W</b>	Water/air service													
<b>Body/connection style</b>														
<b>S</b>	2 side inlets/bottom outlet - w/NPT connections (Standard)													
<b>B</b>	2 side inlets/bottom outlet - w/BSPT connections (Special)													
<b>E</b>	1 side inlet/bottom outlet - w/NPT connections (standard body with one side plugged)													
<b>Spring chamber style</b>														
<b>S</b>	Standard													
<b>C</b>	W/pressure screw cap													
<b>D</b>	W/pressure screw cap and differential connection													
<b>V</b>	Vented													
<b>I</b>	W/pressure screw cap and inverse differential connection (lower pressure plate)													
<b>L</b>	W/pressure screw cap and dome load connection (no pressure spring)													
<b>Spring chamber material</b>														
<b>Z</b>	Bronze	<b>G</b>	316 Stainless steel											
<b>F</b>	Iron													
<b>Diaphragm material</b>														
<b>B</b>	Buna-N	<b>M</b>	Monel®											
<b>Z</b>	Bronze (FR and FR-6 only)	<b>V</b>	Viton® (FR10 only)											
<b>G</b>	316 Stainless steel (FR and FR-6 only)	<b>L</b>	Buna-N w/ Teflon diaphragm liner											
<b>Body seat material</b>														
<b>E</b>	303 Stainless steel	<b>Z</b>	Brass											
<b>G</b>	316 Stainless steel													
<b>Pressure screw style</b>														
<b>S</b>	Standard	<b>T</b>	T-handle											
<b>Variation</b>														
<b>01</b>	Standard (303 Stainless steel trim) (elastomer diaphragms only)													
<b>02</b>	303 Stainless steel trim w/Buna-N O-ring and Aramid fiber diaphragm gasket (metal diaphragms only)													
<b>03</b>	303 Stainless steel trim w/Teflon O-ring and Aramid fiber diaphragm gasket (metal diaphragms only)													
<b>04</b>	303 Stainless steel trim w/Teflon O-ring and Teflon diaphragm gasket (metal diaphragms only) (FR-10 has Teflon diaphragm liner in place of gasket)													
<b>05</b>	303 Stainless Steel Trim w/ Viton® O-Ring & Aramid fiber diaphragm gasket (metal diaphragms only)													
<b>11</b>	316 Stainless steel trim (elastomer diaphragms only)													
<b>12</b>	316 Stainless steel trim w/Buna-N O-ring and Aramid fiber diaphragm gasket (metal diaphragms only)													
<b>13</b>	316 Stainless steel trim w/Teflon O-ring and Aramid fiber diaphragm gasket (metal diaphragms only)													
<b>14</b>	316 Stainless steel trim w/Teflon O-ring and Teflon diaphragm gasket (metal diaphragms only) (FR-10 has Teflon diaphragm liner in place of gasket)													
<b>15</b>	316 Stainless Steel Trim w/Viton® O-ring & Aramid fiber diaphragm gasket (metal diaphragms only)													
<b>31</b>	Nitralloy trim (elastomer diaphragms only)													
<b>32</b>	Nitralloy trim w/Buna-N O-ring and Aramid fiber diaphragm gasket (metal diaphragms only)													
<b>Design revision</b>														
<b>(-)</b>	Indicates original design													
<b>Spring material</b>														
<b>D</b>	Carbon steel (water/air)	<b>E</b>	Stainless steel (optional)											
<b>Spring range</b>														
	Refer to tables on the next page													

Viton® is a mark owned by E.I. du Pont de Nemours and Co.  
 Monel® is a mark owned by Special Metals Corporation.

## CASH VALVE SERIES FR BACK PRESSURE VALVES

### STANDARD SPRING RANGES (PSIG)

Type	Spring material	Size	1	2	3	4	5	6	7
FR	Steel	1/2"	0-25	25-45	5-50	30-100	75-175	150-400	----
		3/4"	0-10	5-20	10-50	20-110	30-200	100-250	150-400
		1"	0-20	10-35	20-90	40-125	50-230	175-380	300-400
		1 1/4"	0-15	10-30	20-85	50-230	175-380	300-400	----
		1 1/2", 2"	0-10	5-20	10-55	30-100	40-200	125-300	200-400
	SST	1/2"	0-20	10-50	40-90	75-200	100-300	100-400	----
		3/4"	0-10	0-15	10-70	50-175	100-265	----	----
		1"	0-15	10-35	20-75	40-200	50-250	----	----
		1 1/4"	0-15	10-30	20-85	40-125	50-250	----	----
		1 1/2", 2"	0-15	5-20	10-55	30-100	40-160	100-250	----

### STANDARD SPRING RANGES (PSIG)

Type	Spring material	Size	1	2	3	4	5
FR-10	Steel	1/2"	0-25	5-50	30-100	75-175	100-250
		3/4"	0-10	10-50	20-110	30-150	100-250
		1", 1 1/4"	0-20	20-90	40-125	50-250	----
		1 1/2", 2"	0-10	10-55	30-100	40-200	125-250
	SST	1/2"	0-20	10-50	40-90	75-200	100-250
		3/4"	0-10	10-70	50-175	100-250	----
		1", 1 1/4"	0-15	10-75	40-200	50-250	----
		1 1/2", 2"	0-15	10-55	30-100	40-160	100-250

### STANDARD SPRING RANGES (PSIG)

Type	Spring material	Size	1
FR-6	Steel	All sizes	200-600
	SST	1/2"	200-600
		3/4", 1", 1 1/4", 1 1/2", 2"	200-400

# CASH VALVE SERIES FR BACK PRESSURE VALVES

## SELECTION GUIDE

Example:	FRM-	A	W	Z	S	Z	S	B	F	02	-	D	1
<b>Model</b>													
<b>FRM-</b> FRM													
<b>FRM2</b> FRM-2													
<b>Size</b>													
<b>A</b> ¼" (All)													
<b>B</b> ⅜" (All)													
<b>C</b> ½" (FRM-2)													
<b>Service</b>													
<b>W</b> Water/air/oil/gas (FRM and FRM-2)													
<b>Material of construction</b>													
<b>Z</b> Brass													
<b>G</b> 316 SST (FRM and FRM-2)													
<b>Body/connection style</b>													
<b>S</b> Side inlet/side outlet (All) NPT													
<b>R</b> 2 side inlets/bottom outlet (FRM and FRM-2) NPT													
<b>E</b> Side inlet/bottom outlet (FRM and FRM-2) NPT													
<b>Spring chamber material</b>													
<b>A</b> Aluminum spring chamber (FRM)													
<b>Z</b> Brass spring chamber													
<b>C</b> Chrome-plated													
<b>Spring chamber style</b>													
<b>S</b> Standard													
<b>C</b> Cap (FRM-2)													
<b>W</b> Without vent hole													
<b>Diaphragm material</b>													
<b>B</b> Buna-N													
<b>N</b> Neoprene													
<b>V</b> Viton®													
<b>G</b> 316 Stainless steel													
<b>Z</b> Bronze													
<b>Pressure screw style</b>													
<b>F</b> Fillister (FRM only)													
<b>H</b> Hex													
<b>Q</b> Square head (Steel for W/A service only)													
<b>Variation</b>													
<b>01</b> Standard (303 Stainless steel trim) (elastomer diaphragms only)													
<b>02</b> 303 Stainless steel trim w/Aramid fiber diaphragm gasket (metal diaphragms only)													
<b>03</b> 303 Stainless steel trim w/Teflon diaphragm gasket (metal diaphragms only)													
<b>05</b> 303 Stainless steel trim w/nylon inserted locknut													
<b>11</b> 316 Stainless steel trim (elastomer diaphragms only)													
<b>12</b> 316 Stainless steel trim w/Aramid fiber diaphragm gasket (metal diaphragms only)													
<b>13</b> 316 Stainless steel trim w/Teflon diaphragm gasket (metal diaphragms only)													
<b>21</b> Monel® trim (elastomer diaphragms only)													
<b>22</b> Monel® trim w/Aramid fiber diaphragm gasket (metal diaphragms only)													
<b>23</b> Monel® trim w/Teflon diaphragm gasket (metal diaphragms only)													
<b>31</b> Brass body w/SST body seat													
<b>32</b> Remote sensing													
<b>UL</b> UL approved													
<b>Design revision</b>													
<b>(-)</b> Original design													
<b>Spring material</b>													
<b>D</b> Carbon steel (industrial or final line gas service only)													
<b>E</b> Stainless steel (FRM-2)													
<b>Spring range</b>													
Refer to table on below													

## STANDARD SPRING RANGES (PSIG)

Spring material	Model	1	2	3	4	5	6	7	8	9
Steel	FR	1-2	2-15	2-30	10-50	40-90	40-125	75-175	----	----
SST	FR	2-25	15-65	40-100	50-150	75-175	100-250	200-400	200-600	300-600
	FRM2	0-30	20-50	40-80	75-150	100-275	200-400	300-600	----	----

Viton® is a mark owned by E.I. du Pont de Nemours and Co.  
 Monel® is a mark owned by Special Metals Corporation.

VCTDS-00516-EN © 2016, 2021 Emerson Electric Co. All rights reserved 09/21. Cash Valve is a mark owned by one of the companies in the Emerson Automation Solutions business unit of Emerson Electric Co. The Emerson logo is a trademark and service mark of Emerson Electric Co. All other marks are the property of their prospective owners.

The contents of this publication are presented for informational purposes only, and while every effort has been made to ensure their accuracy, they are not to be construed as warranties or guarantees, express or implied, regarding the products or services described herein or their use or applicability. All sales are governed by our terms and conditions, which are available upon request. We reserve the right to modify or improve the designs or specifications of such products at any time without notice.

Emerson Electric Co. does not assume responsibility for the selection, use or maintenance of any product. Responsibility for proper selection, use and maintenance of any Emerson Electric Co. product remains solely with the purchaser.

[www.Emerson.com](http://www.Emerson.com)