

2000HP Multi-turn Direct Gas Pipeline Pneumatic Actuators

High pressure gas power for rapid response for gate and large bore quarter-turn valves



Designed to handle every high pressure valve control need on your pipeline

The EIM 2000HP pneumatic actuator from Emerson is a multi turn gas driven actuator that is perfect for applications using linear, rising stem or rotating stem valves. Developed for operation in the natural gas industry, the 2000HP actuates pipeline valves using the pipeline's own gas pressure as its power source.

The robust actuator is based on the proven EIM Series 2000 platform, with more than a half-century of outstanding field performance around the globe. It has the most durable internal components in the industry, assuring long-term reliability.

Widely used throughout all industries since the 1970s, the 2000HP is well suited for any industrial or pipeline application where compact design, simple manual override, travel limits, and torque protection are desired. It is ideal for situations such as compressor stations where electric motors would disrupt cathodic protection systems.

The 2000HP can handle virtually any local or remote control system requirement. A variety of standard single or double acting pneumatic and electric remote control configurations are available with optional electric limit switches.

The actuator, as an independent unit, is capable of producing 1,200 ft/lb (1,626 Nm) and 45,000 lb (200.18 kN) of thrust. Torque outputs up to 135,000 lb/ft (183,036 Nm) and thrust outputs up to 900,000 lbs (4,003.6 kN) can be attained through the addition of bevel or worm gearboxes.

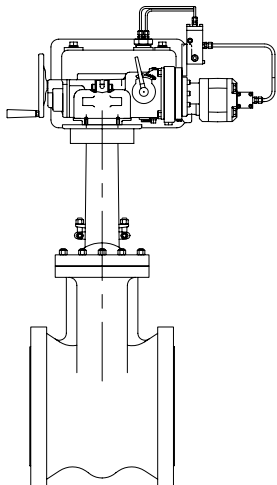

2000HP is distinctive

- Adaptable to quarter-turn or multi-turn applications
- Directly mountable on rising stem valves
- Manual override, travel limits and torque protection are standard
- Highly visible position indication dial available when using electric control pack
- Usable with bevel or worm gears
- Local/remote controls
- Padlockable clutch handle in either hand or motor position
- Handwheel operation in power loss or emergency operation
- Corrosion resistant valving
- MSS or ISO mounting flanges

2000HP offers numerous benefits

- More economical than linear piston actuators
- Provides reliable emergency shutdown service
- Can be equipped for operation with nitrogen or natural gas
- Hundreds of torque/thrust/speed combinations available
- Compact design for space saving installations
- Mechanically locks valve in place when idle
- Eliminates hydraulic manual override



2000HP Features

- Built using the same rugged design of the EIM Series 2000 electric actuator

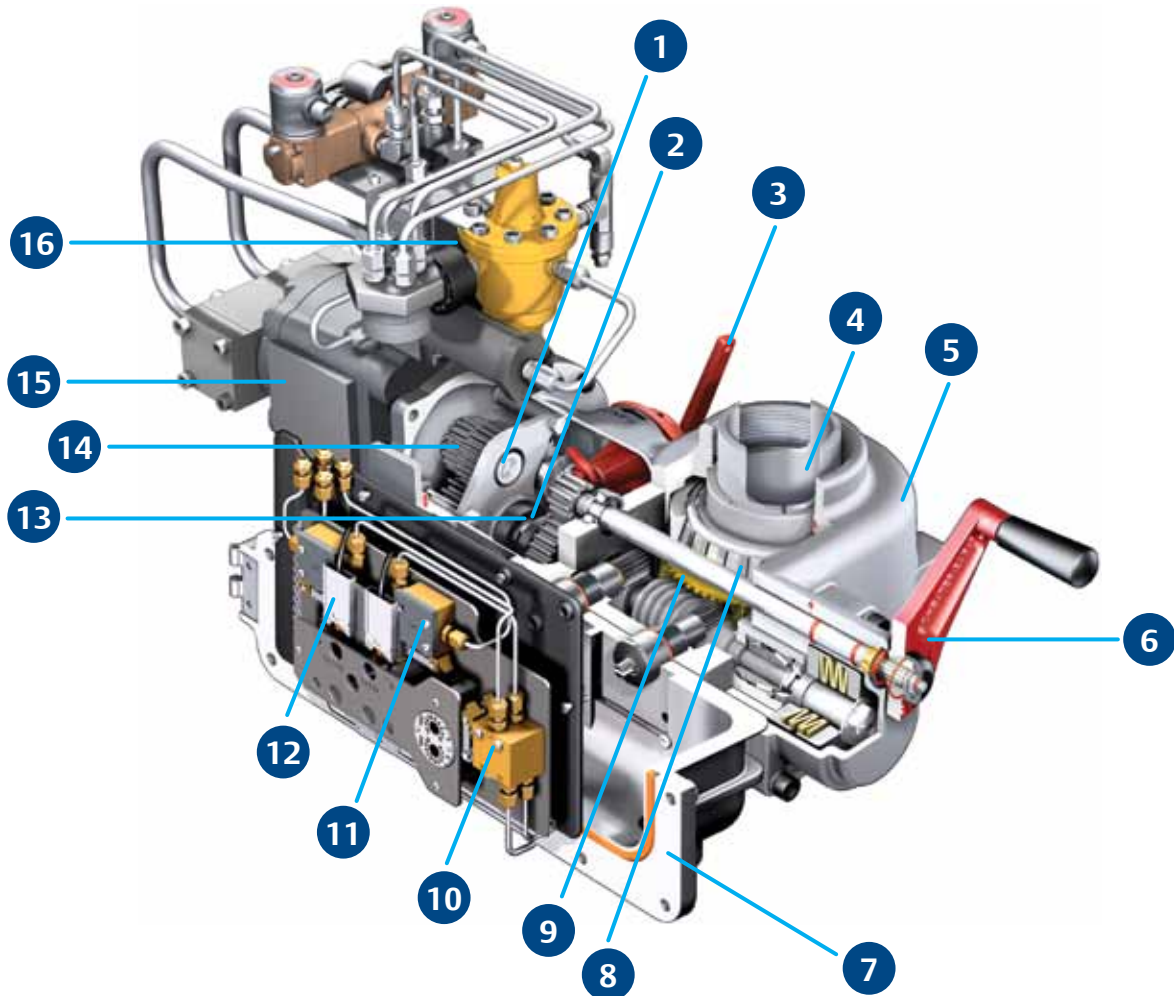

Rugged features are integral to the 2000HP design

- | | |
|---|--|
| 1 Bearing supported shafts (no bushings) | 9 Permanently self-locking worm and wheel |
| 2 Automatic motor priority | 10 Torque protection (internal and standard) |
| 3 Low declutch force | 11 Travel limits (internal and standard) |
| 4 Valve stem never disengages from the drive sleeve | 12 Position indication (optional) |
| 5 Ductile iron housing | 13 Low torque side declutching |
| 6 Low rim-pull (80 lbs/350N maximum) | 14 Alloy steel motor gear selections allow numerous speed and torque output combinations |
| 7 Hinged cover, O-ring sealed controls enclosure | 15 High pressure gear motor |
| 8 Tapered top and bottom roller bearings | 16 Pressure regulator and manually-operated selector valve are protected in a stainless steel padlockable control box-standard (not shown) |

2000HP Control details

- Control power supply regulated to 100 psi (6.9 Bar)
- Motor and pilot block supply pressure 1,480 psi (102 Bar) maximum
- Local control function utilizing manually-operated selector valve
- Meets ingress protection classification IP66



Control options

- Optional electrical position indication switches available. Switch certification rating: II 2g Ex d IIc T6; IID Ex tD A21 IP66 T80C
- Optional electric remote operation available. Solenoid certification rating: Class I, Div I, Grp C&D; Class II, Div I Grp E, F, G. ATEX certified solenoids available on request
- Custom control schemes available

Contact Us: Emerson Process Management, Valve Automation facilities at your nearest location:

NORTH AMERICA

13840 Pike Road
Missouri City, Texas 77489 USA
T+1 281 499 1561 (Toll Free USA)
T+1 281 499 1561
F+1 281 499 8445
info.missouricity@emerson.com

MIDDLE EAST & AFRICA

P.O. Box 17033
Dubai
United Arab Emirates
T +971 4 811 8100
F +971 4 886 5465

EUROPE

Asveldweg 11
7556 BR Hengelo (O)
The Netherlands
T +31 74 256 1010
F +31 74 291 0938

Via Montello 71/73
20038 Seregno (Milan)
Italy
T +39 0362 2285 207
F +39 0362 2436 55

ASIA PACIFIC

No. 9 Gul Road
#01-02 Singapore 629361
T +65 6501 4600
F +65 6268 0028

1277 Xin Jin Qiao Road
Jin Qiao Export Processing Zone
Shanghai 201206
P.R.China
T +86 21 2892 9000
F +86 21 2892 9001

For technical data and local representation, please check our website: www.eim-co.com

© 2013 Emerson Process Management. All rights reserved.

The Emerson logo is a trademark and service mark of Emerson Electric Co. "Brand mark listing" are marks of one of the Emerson Process Management family of companies. All other marks are property of their respective owners.

The contents of this publication are presented for information purposes only, and while every effort has been made to ensure their accuracy, they are not to be construed as warranties or guarantees, express or implied, regarding the products or services described herein or their use or applicability. All sales are governed by our terms and conditions, which are available on request. We reserve the right to modify or improve the designs or specifications of our products at any time without notice.



E8K-101-0313

www.eim-co.com

EMERSON[™]
Process Management