

G-Series Pneumatic and Hydraulic Actuators

The Latest Generation in Valve Automation Solutions



BETTIS™

EMERSON™
Process Management



Bettis G-Series
with Wireless Transmitter

Emerson Process Management – Valve Automation sets the standards for innovation and quality in pneumatic and hydraulic valve automation.

Bettis G-Series actuators are lightweight, efficient and reliable - all in a compact, modular package.

G-Series are available with either symmetric or canted yokes to suit your operating requirements.



Bettis G-Series
with Topworx Positioner

Design and Construction

Emerson Process Management – Valve Automation has been the pioneer in valve actuation innovation for more than 55 years. The broad product offering, high quality standards and a proven performance track record, make us the perfect choice for reliable valve automation. A wide range of industries, including the oil and gas, chemical, refining, pulp & paper, water & wastewater, power generation, nuclear and other industries all rely on Emerson's Bettis brand.

G-Series pneumatic and hydraulic actuators provide global customers with the latest in valve actuation design. It is a highly unique and reliable means of operating ball, butterfly or plug valves along with louvers, dampers and other 90 degree rotating mechanisms. G-Series actuators are back by a five-year materials and workmanship warranty, the best in the industry.

G-SERIES SERIES APPLICATION AND FEATURES

- The actuators are PED 97/23/EC compliant to meet the stringent requirements of pressure mounting vessels.
- G-Series actuators meet both IP66 and IP67M specifications for submergence and high pressure water deluge test. This offers superior water ingress and corrosion protection.
- The actuator has suitability for use within the demanding applications of a SIL environment.
- G-Series is available in both spring-return or double-acting configurations and can operate with either a symmetric or canted yoke.
- G-Series offers multiple configurations, with a modular design that enables safe field maintenance and reduced inventory costs.
- The actuator optimizes the center of gravity location to be lighter and more compact than other actuators of equal torque output – 1/3 lighter and 1/2 smaller.
- G-Series has interchangeable power and spring modules for quick reversal of the fail-safe mode.
- Close Loop Instrument System for actuators is strongly recommended for the following applications: High humidity; Salt air; Corrosive dust; Inks and dyes; Wash Downs. The closed loop system routes the operating media being exhausted from the power side of the cylinder to the vented side of the cylinder. Maximum pressure on the vented side of the power cylinder is to be 5 to 8 psig.
- 5-Year Warranty.

Operating Ranges

G-Series has guaranteed torque outputs for spring-return models in excess of 3,000,000 lb-in (339,000 Nm) and double-acting 12,581 – 6,000,000 lb-in (1420 – 678,000 Nm). Operating pressures are:

Pneumatic – 40-220 psig (3-14 Bar)

Hydraulic – to 5,000 psig (345 Bar)

Standard Trim	High Temp. Trim (-10)	Low Temp. Trim (-11)	
None-PED and PED		None-PED	PED
-20°F to +200°F	0°F to +350°F	-40°F to +150°F	Consult Factory
-29°C to +93°C	-18°C to +177°C	-40°C to +66°C	

Reduces Wear

The Power-Swivl™ piston rod and guide block connection compensates for side load deflection and reduces wear. Seal-lubricating bearings protect sliding and rotating components.

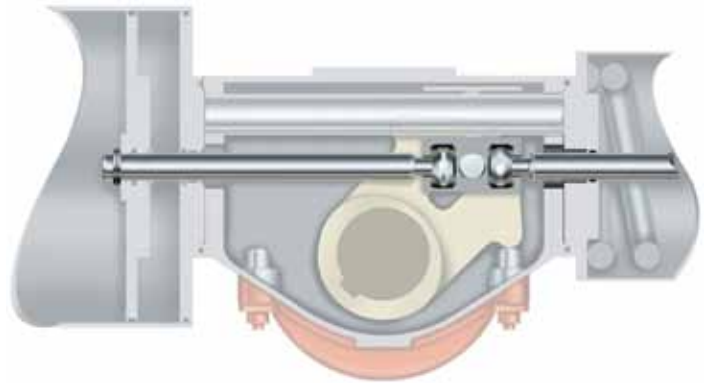

Power-Swivl™

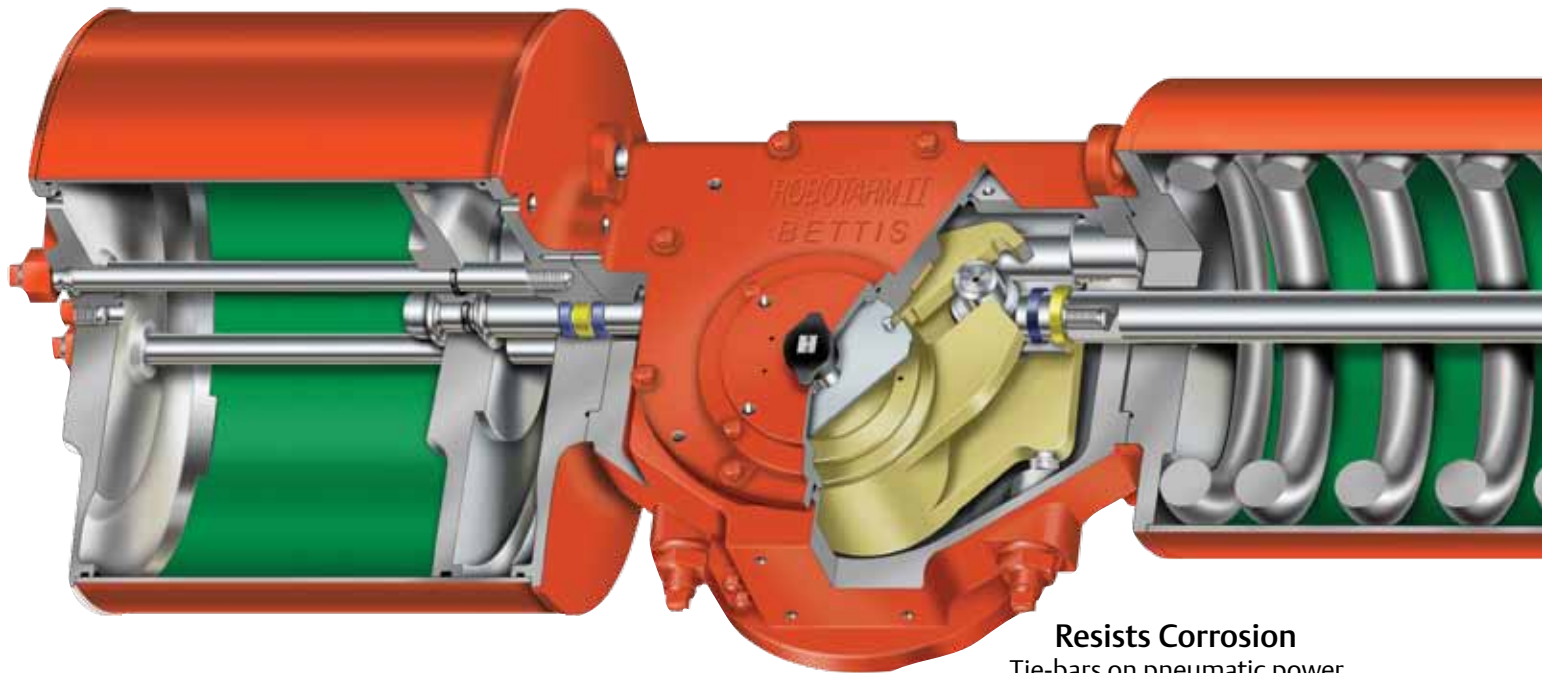

Resists Corrosion

Tie-bars on pneumatic power modules are corrosion resistant, and internal and external surfaces are coated to protect in harsh environments.

Promotes Safety

The patented Tension-Lok™ device positively locks the spring module to allow its safe removal and installation, eliminating accidental release of the spring force.

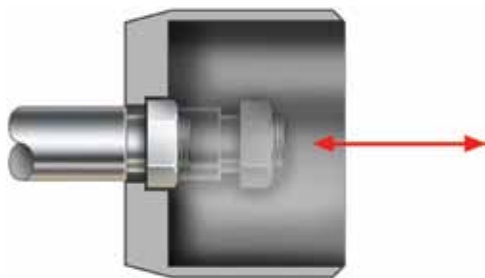

Tension-Lok™

Seals Positively

With dual drive module vent checks, breather seals, total O-ring sealing and no gaskets, the G-Series prevents water ingress and seals out the environment.

Bi-Directional Travel Stops

Integral bi-directional travel stops, adjustable from 80° to 100° of total valve travel, assist the G-Series in prolonging valve seat integrity.

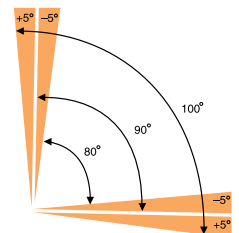

Other G-Series Solutions

GS-Series

Bettis actuators have long been a preferred brand for use in marine environments. The GS-Series actuators are well suited for splash zone, riser and other offshore fail-safe applications. They are available with diver or ROV intervention systems.



NG-Series

Bettis actuators were perhaps the first ever qualified for nuclear service, meeting IEEE 382 standards more than 40 years ago. NG-Series actuators have been independently tested to include LOCA (Loss of Cooling Accident), seismic, and various aging processes required to meet current nuclear qualification criteria.

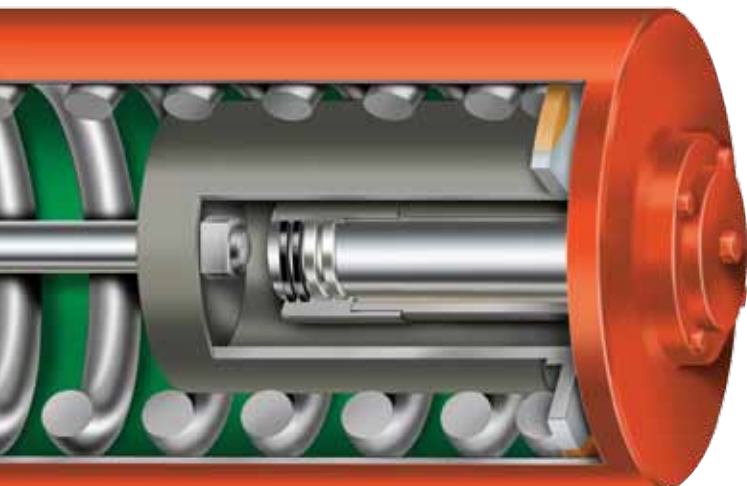

GH-Series

The GH-Series actuators provide specialized higher maximum operating pressures (MOP) where required. Available in either canted (model GHC) or symmetric (GH) yoke configurations for spring-return, fail-safe projects. An optional SRO spring is available for higher spring start and end torques.

Safety Integrity Level (SIL)

Bettis G-Series actuators are used within demanding SIL applications. They have a Failure Modes and Effects Diagnosis Analysis (FMEDA) report performed by Exica.com for SIL suitability. With the addition of Fisher's TÜV-certified FIELDVUE™ controller, the G-Series can be partial stroke tested and continuously monitored to verify its proper working condition, making it suitable for controlling final control elements in SIL 1,2 or 3 applications.

Jackscrew is available for the G1, G2, and G3

Bettis offers a variety of mechanical and manual overrides for G-Series models. The M11 hydraulic override can be used with either spring-return pneumatic or hydraulic models. The M3 jackscrew manual override for G1, G2, and G3 models is available with or without handwheel.

Symmetric or Canted Yokes

Bettis G-Series actuators are available with either symmetric or canted yokes. The traditional symmetric yokes provide efficient operation at both the break and end positions. Canted (or inclined) yokes have a torque advantage in applications where higher break torque is needed to unseat the valve, with less critical needs at the run or full open positions.

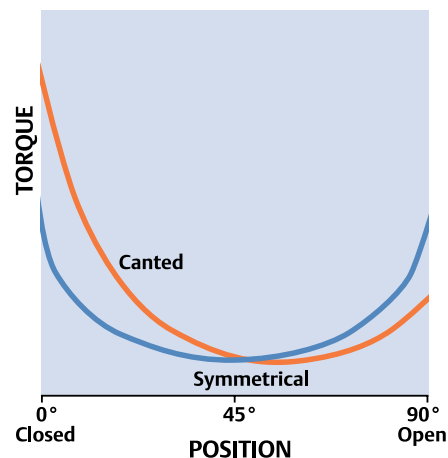

Symmetric Yoke



Canted Yoke

Emerson brands for most common control accessories:

Digital Valve Controllers:	Fisher®
Positioners:	Fisher®
Regulators:	Fisher®
Switch boxes:	TopWorx
Wireless position monitor:	TopWorx
Solenoid valves:	ASCO Numatics™

For more detailed technical information see our online documentation under www.Bettis.com/technical-data

Options

Overrides

Bettis offers a variety of mechanical and manual overrides for G-Series models. The M11 hydraulic override can be used with either spring-return pneumatic or hydraulic models. The M3 jackscrew manual override for G1, G2 and G3 models is available with or without handwheel. The G-Ride (shown) is an economical external non-declutchable mechanical override for G4 and G5 spring-return models available with standard hex nut or handwheel.



Automated Packages

Bettis offers complete valve operating systems for final valve control. At our World Area Configuration Centers (WACC), we combine the G-Series actuator, controls and a valve in a single system. We can integrate a complete controls offering including world-class PlantWeb® digital plant architecture. We also supply BettiSystems™, pre-engineered and documented controls packages, available at our WACC for reducing lead times, simplifying purchasing and easing installation.



Modular Versatility

- Enables Online Field Maintenance
- Lowers Inventory

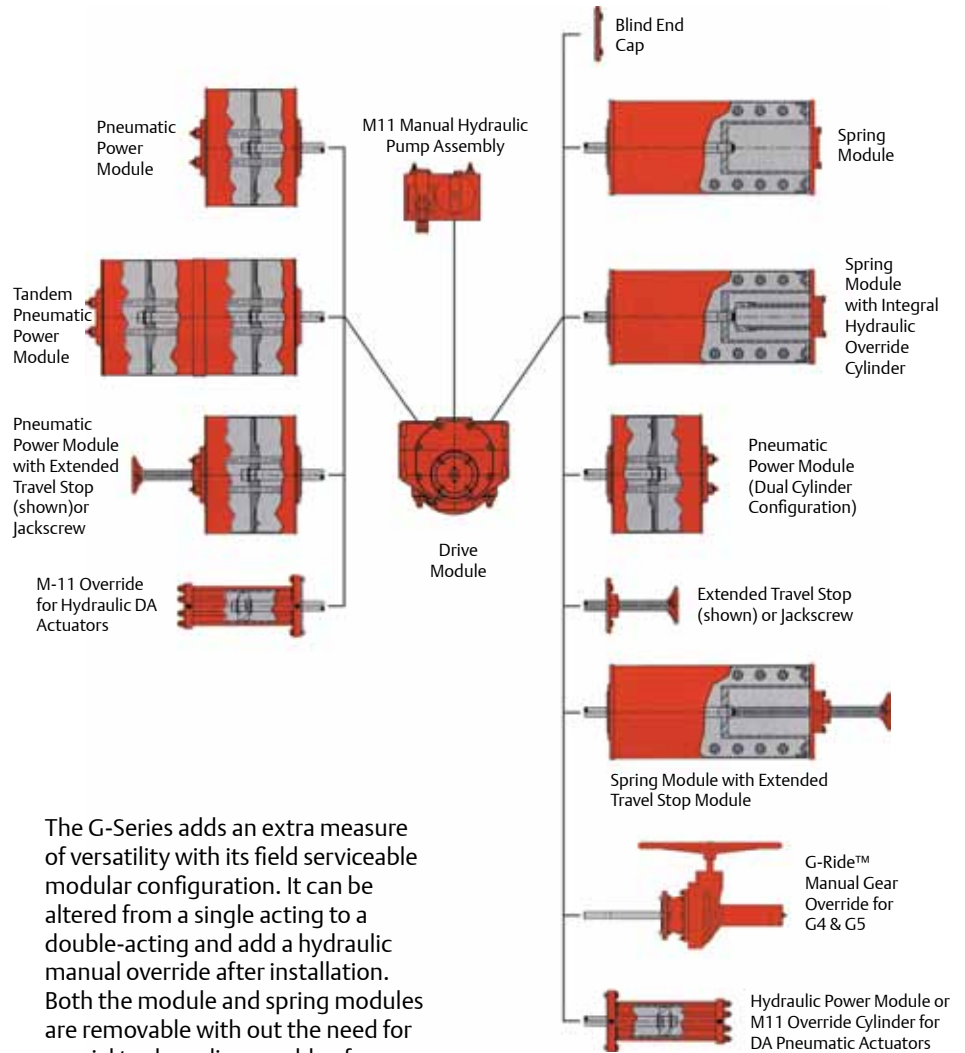

The G-Series adds an extra measure of versatility with its field serviceable modular configuration. It can be altered from a single acting to a double-acting and add a hydraulic manual override after installation. Both the module and spring modules are removable without the need for special tools or disassembly of any modules. Modules can be purchased separately at an Emerson World Configuration Center and can be serviced at your own maintenance facility.

Note: The above graphic does not necessarily depict all modular orientations. Consult Factory for certified dimensional drawings.

STANDARDS AND CERTIFICATIONS

Bettis G-Series actuators are manufactured to meet the following worldwide quality and safety standards:



PED/97/23/EC –
Pressure
Equipment
Directive

World Area Configuration Centers (WACC) offer sales support, service, inventory and commissioning to our global customers. Choose the WACC or sales office nearest you:

NORTH & SOUTH AMERICA

19200 Northwest Freeway
Houston, TX 77065
T +1 281 477 4100
F +1 281 477 2809

Av. Hollingsworth,
325, Iporanga Sorocaba,
SP 18087-105
Brazil
T +55 15 3238 3788
F +55 15 3228 3300

ASIA PACIFIC

No. 9 Gul Road
#01-02 Singapore 629361
T +65 6501 4600
F +65 6268 0028

No. 1 Lai Yuan Road
Wuqing Development Area
Tianjin 301700
P. R. China
T +86 22 8212 3300
F +86 22 8212 3308

MIDDLE EAST & AFRICA

P. O. Box 17033
Dubai
United Arab Emirates
T +971 4 811 8100
F +971 4 886 5465

P. O. Box 10305
Jubail 31961
Saudi Arabia
T +966 3 340 8650
F +966 3 340 8790

24 Angus Crescent
Longmeadow Business Estate East
P.O. Box 6908; Greenstone;
1616 Modderfontein, Extension 5
South Africa
T +27 11 451 3700
F +27 11 451 3800

EUROPE

Asveldweg 11
7556 BR Hengelo (O)
The Netherlands
T +31 74 256 1010
F +31 74 291 0938

For complete list of sales and manufacturing sites, please visit
www.emersonprocess.com/valveautomationlocations
Or contact us at info.valveautomation@emerson.com

©2014 Emerson Process Management. All rights reserved.

The Emerson logo is a trademark and service mark of Emerson Electric Co. Bettis™ is a mark of one of the Emerson Process Management family of companies. All other marks are property of their respective owners.

